



Over 50 Years of Family Tradition and Values

Product Catalog

Heavy Glass Enclosures

Our heavy glass shower enclosures use 3/8" and/or 1/2" tempered glass that add a level of depth and luxury to every bathroom. Their bold presence and timeless simplicity often give spa-like impressions to homeowners and guests. These enclosures can match any style or personal touch with near limitless options available.

Features

- 3/8" and/or 1/2" glass thickness with high-polished edges
- Domestic aircraft-grade aluminum channels
- Through-glass handles available in a variety of sizes, colors, and styles
- Wall-mount, glass-mount, and pivot hinges in solid brass are available
- Engineered doors, panels, notched panels, and transoms are available
- Customized panels can include channel or clip anchoring systems
- Variety of glass types are available
- Glass protection available
- Hardware upgrades, such as specialty finishes and styles, are available



Pivot to Ceiling Hinge System, Channel-Set Panels



Wall-Mount Hinge System, Recessed Channel-Set Panels



Pivot Hinge System, Clip- and Channel-Set Panels



Wall-Mount Hinge System, Channel-Set Panels



Wall-Mount Hinge System, Channel-Set Panels



Pivot-to-Header Hinge System, Channel-Set Panels



3/8" and 1/2" Euroglide System



3/8" Hydroslide System



3/8" Semi-Frameless Bypass System

Sliding Enclosures

Our world class sliding glass shower doors, available in framed, semi-frameless, and frameless styles, allow easy access when space is limited.

Features

- Engineered for 3/16", 1/4", 3/8", or 1/2" glass
- Towel bars available in frame-mounted (for framed units) and through-glass styles with standard and arch options
- Finger-pull, pull-handles, recessed-knob, and standard-knob options available
- Domestic aircraft-grade aluminum hardware
- Variety of glass types in stock
- Can be engineered to accommodate adjoining panels
- Specialty systems include Hydroslides, Euroglides, and header-less Essence enclosures
- Glass protection available



1/2" Essence System



Framed Bypass System



1/4" Semi-Frameless Bypass System

Framed Enclosures

Simple, classic, and mechanically durable, our framed enclosures are engineered to last a lifetime. From just a simple door to an expanded multi-angle wrap-around enclosure, framed enclosures are often one of the best and most economical design choices a homeowner can make.

Features

- 1/4" glass used for panels – heavier, thicker, and more durable than the industry standard
- Constructed using matching framed door hardware
- Domestic aircraft-grade aluminum hardware
- Variety of glass types in stock
- Glass protection available
- Hardware upgrades, such as specialty finishes and styles, are available



Framed Door and Panel System



Framed Door and Panel System

Semi-Frameless Enclosures



Semi-Frameless System with 6" C-Pull Handle

Semi-frameless shower enclosures are often the best way to meld elegant form and practical function at an affordable price. The key feature is the door: our doors open on a concealed hinge that allows a stunning, seamless presentation of the glass. With several handles and a variety of style options available, a semi-frameless enclosure can dramatically improve or compliment an entire bathroom.

Features

- 1/4" glass throughout entire enclosure
- Polished-edge door with concealed hinge
- Through-glass or knock-on handles available in a variety of sizes, colors, and styles
- Domestic aircraft-grade aluminum hardware
- Panels can be engineered to join without hardware creating an aquarium-like feel
- Variety of glass types in stock
- Glass protection available
- Hardware upgrades, such as specialty finishes and styles, are available



Semi-Frameless System with 6" C-Pull / 18" Towel Bar Combo

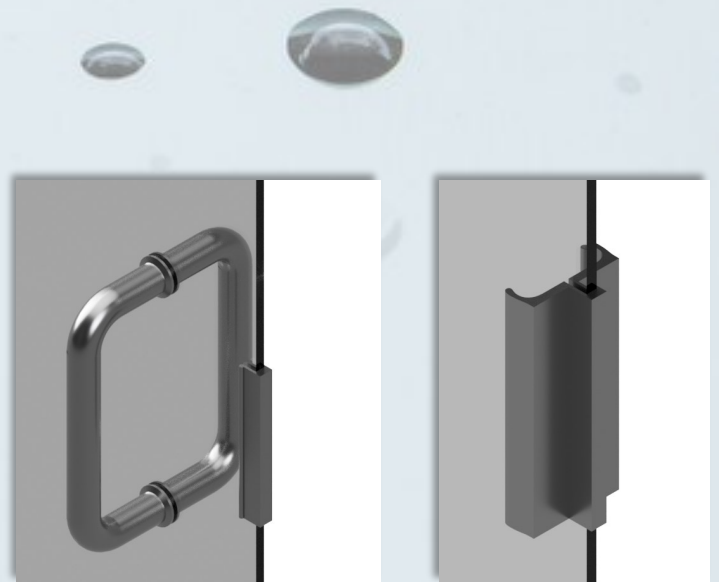

*Upgraded C-Pull Handle (left)
and Knock-On Handle (right)*

Hardware Options

All of our hardware is an elegant blend of function and design and is built to last throughout the life of your shower.

Quality Enclosures prides itself on offering the latest, most up-to-date designs in the industry. With thousands of options available and over 55 years of experience, we can provide the option that best fits your décor and design. Contact one of our Customer Service Representatives or your dealer to explore the possibilities.

Heavy Glass Hardware Plated Finishes



Powder Coat Finishes



Heavy Glass Hardware

We offer hundreds of hardware options—contact one of our Customer Service Representatives for details.



Standard C-Pull



H-Pull / Ladder Pull



Mitered Round Pull



Mitered Square Pull



Arch Style Pull



Traditional Pull



Wall Mount with Short Back Plate



Wall Mount with Full Back Plate



Jamb Mount Hinge System



Wall Mount Pivot



Pivot Hinge (Header)



Wall Mount with Offset Back Plate



135° Glass to Glass



180° Glass to Glass



90° Glass to Glass



Pivot Hinge (Curb)

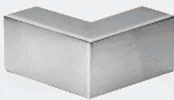

90° Sleeve-Over



Square Wall Mount

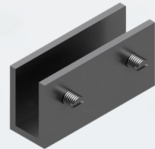

No-Fab with screws



90° Glass to Glass



180° Operable Transom



Adjustable Wall Mount



Standard



Deluxe

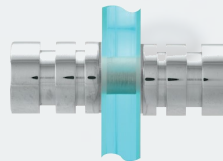

Contemporary

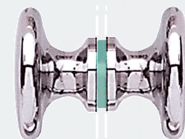

Traditional



Standard Towel Bar



Towel Bar/C-Pull Combo



Traditional Towel Bar

Glass Tempering

Our in-house tempering facilities enable us to provide glass for a wide variety of residential and commercial needs. Every piece is carefully engineered and meticulously fabricated to provide the highest quality material specified by our customers.

Features

- 3/16", 1/4", 3/8", and 1/2" glass in stock
- Complete fabrication capability including polishing; mitering; hole, notch, and specialty shape cutting
- Variety of glass types in stock
- Fast, reliable turnaround of all orders
- All glass is created with only premium domestic materials
- Multiple tempering locations
- High-volume capabilities
- Each piece of glass is stamped with the Quality Enclosures Tempering logo during our quality control process

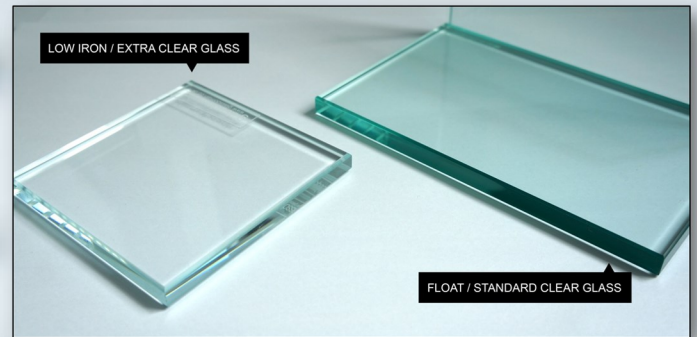

Starphire / Low Iron

Clear (standard)



Pattern 62

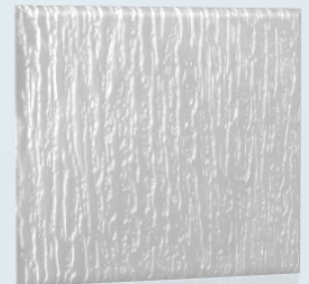

Rain



Acid Etched

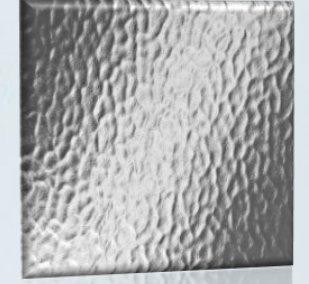

Aquatex

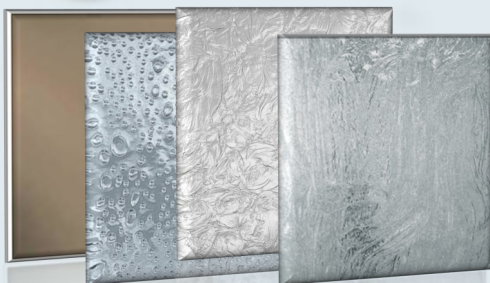

Specialty glass types such as Bronze, Bubble, Glue Chip, Storm, and more are available at select locations—contact one of our Customer Service Representatives or your dealer for availability and pricing.

Properly protecting the surface of glass is a necessary step to ensure your enclosure maintains its brand-new look. Our options for protecting the glass reduce maintenance time dramatically and avoid the use of costly, harsh chemicals during routine cleaning. We offer two options for protection: HydroShield, which carries a five-year limited warranty and is coated on both sides of the glass, and ShowerGuard, which offers a limited lifetime warranty and protects one side of the glass.



HydroShield™
Eco-Friendly Coatings

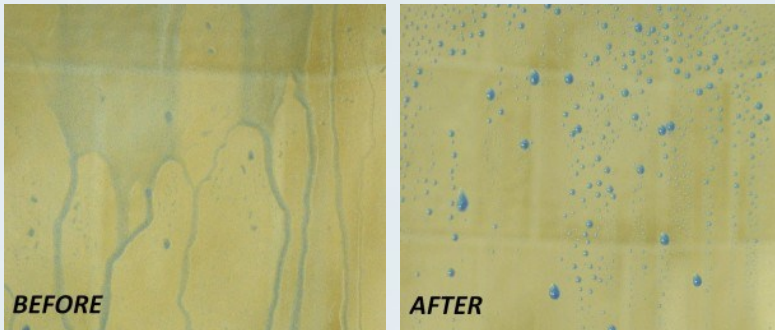

HydroShield is a protective coating available on all types of glass, keeping residue from building within the pores of the material.

- Reduces maintenance time by up to 75%
- Clear glass is sealed on both sides
- Pattern glass is sealed on smooth side
- Does not alter the texture or appearance of the glass
- When applied at Quality Enclosures, HydroShield has a five-year manufacturer warranty; additional warranties are available
- On-site application options are available



ShowerGuard is a surface protectant permanently applied during the manufacturing process.

- Drastically reduces maintenance of the glass
- Does not alter the texture or appearance of glass
- Ion-beam processing seals one side of the glass surface when the glass is manufactured
- Permanent application – nothing to reapply and nothing to wear off over time
- Available for Clear and Low-Iron glass types
- Lifetime glass warranty





The Quality Promise

Quality Enclosures, Inc. is a family owned and operated company based on family traditions and values. These attributes contribute to our long-standing reputation as a respected leader in the shower door industry. We manufacture and fabricate a complete line of shower and tub enclosures using superior workmanship and the highest quality materials. Whenever we produce a shower door or enclosure, we treat it – from the very beginning of the process to the very end – as if it was going into our own home.

Warranty

Quality Enclosures, Inc. offers a limited 3 year warranty to the purchaser of any new aluminum shower door or any new aluminum shower door part manufactured by Quality Enclosures, Inc. that the product or part shall be free from defects in material and workmanship. Quality Enclosures, Inc. agrees to repair or replace any defective part at no charge to the purchaser within the warranty period. This warranty does not cover damage resulting from normal wear from usage, loss, alteration, accident, misuse or abuse, or lack of reasonable care in either the installation or use of the product or parts.

No responsibility is assumed by Quality Enclosures, Inc. for any special, incidental or consequential damages. If there is any defect in workmanship or material, Quality Enclosures, Inc.'s liability is solely limited to replacement of material as stated. Quality Enclosures, Inc. reserves the right to decide if the defective part or product is to be replaced or repaired. Any and all claims for replacement and / or rework must be pre-approved by Quality Enclosures, Inc.



Over 50 Years of Family Tradition and Values

FLORIDA

2025 Porter Lake Drive
Sarasota, FL 34230
p. 1.800.881.0051
f. 941.377.9245

FLORIDA

3028 Mercury Road
Jacksonville, FL 32207
p. 904.503.9022
f. 904.666.5917

GEORGIA

850 Pickens Industrial Dr.
Marietta, GA 30062
p. 770.590.7337
f. 770.590.7338

TENNESSEE

2324 Southpark Drive
Murfreesboro, TN 37128
p. 615.494.0002
f. 615.494.0057

NEW YORK

101-H Windsor Place
Central Islip, NY 11722
p. 631.234.0115
f. 631.234.0174

Proudly Made in the U.S.A.